

Annotation:

This operation bulletin contains updated information regarding mounting of rear wheel hubs on the rear semi-axle of the tractor.

Content of changes:

1. Subsection 3.2.9 “Rear wheel track formation” shall be amended as follows:

The information available:

The bushings are tightened into the hub group housing with six bolts 1 (M20) with a torque from 360 to 450 Nm, clenching the semi-axle.

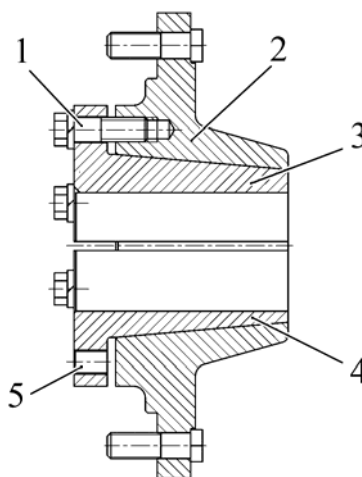

1 – tie bolts; 2 – hub group housing; 3 – upper bushing; 4 – lower bushing; 5 – dis-mounting holes.

Figure 3.2.4 – Rear wheel hub group

Shall be replaced with:

When mounting the wheel hub on the axle shaft bolts 1 shall be tightened with a torque of 360 to 380 Nm in a sequence of 1, 2, 3, 4, 5, 6 (figure 3.2.4b). After you mount the wheel on the hub tighten bolts 1 with a torque of 360 to 400 Nm in the sequence of 1, 2, 3, 4, 5, 6.

ATTENTION: AFTER THE BOLTS ARE TIGHTENED MAKE SURE THE ENDS OF THE TOP AND THE LOWER INSERTS JUT TO A VALUE OF NO MORE THAN 2 MM WITH RESPECT TO EACH OTHER!

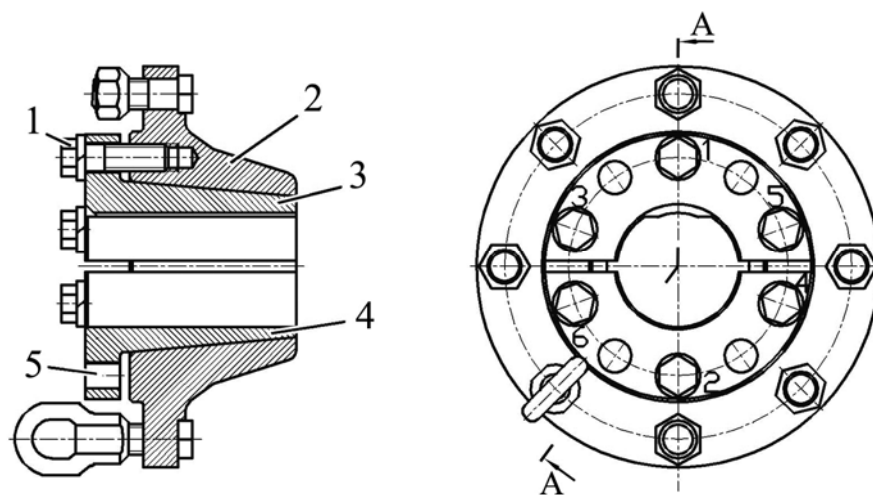

a) wheel hub composition

b) scheme of tightening the bolts that attach wheel hub to axle shaft

1 – tie bolts; 2 – hub group housing; 3 – upper insert; 4 – lower insert; 5 – dismounting holes.

Figure 3.2.4 – Rear wheel hub group

2. Subsection 3.2.9 “Rear wheel track formation” shall be amended as follows:

The information available:

- screw out the tie bolts from the dismounting holes and screw them into the bushings. Screw in the tie bolts with a torque from 360 to 450Nm in stages – until all the bolts are screwed in with the required torque;
- mount the wheel onto the hub group, tighten the wheel retaining nuts with a torque from 300 to 350Nm, set the blind plugs to their places;

Shall be replaced with:

screw out the tie bolts from the dismounting holes and screw them into the inserts. Screw in the bolts with a torque of 360 to 380 Nm in a sequence of 1, 2, 3, 4, 5, 6 (figure 3.2.4b);

- mount the wheel onto the hub group, tighten the wheel retaining nuts with a torque from 300 to 350Nm, set the blind plugs to their places;
- after you mount the wheel on the hub group tighten the bolts with a torque of 360 to 400 Nm in the sequence of 1, 2, 3, 4, 5, 6.



3. Clause 5.4.2.2 “Operation 21. Check of threaded joint tightening of wheel fixing” of subsection 5.4.2 in operation manuals 1523.6-0000010 РЭ and 1523.5-0000010-17 РЭ shall be amended as follows:

The information available:

- tightening torque for bolts 4 (figure 5.4.14) of rear wheel conic hubs shall be from 360 to 450 Nm;

Shall be replaced with:

- tightening torque for bolts 4 (figure 5.4.14) of rear wheel conic hubs shall be from 360 to 400 Nm;

4. Clause 5.4.2.2 “Operation 18. Check of threaded joint tightening of wheel fixing” of subsection 5.4.2 in the operation manual 1523.5-0000010 РЭ shall be amended as follows:

The information available:

- tightening torque for bolts 4 (figure 5.4.10) of rear wheel conic hubs shall be from 360 to 450 Nm;

Shall be replaced with:

- tightening torque for bolts 4 (figure 5.4.10) of rear wheel conic hubs shall be from 360 to 400 Nm;