



# Mounting Kit Instructions

## MTZ 1220

Instruction Sheet: P4734 Mtg Kit: M3949 Loader: MTZL2596E

**Attention:** Be sure to read all notes **BEFORE BEGINNING** installation.

1. Remove packing material. Inspect parts for damage and verify parts supplied with bill of materials.
2. Remove and discard cap plugs from tapped holes and clean thread surface. Verify depth of hole versus bolt provided to ensure bolt doesn't bottom in casting. Typical thread engagement should be 1-1/2 times bolt diameter.
3. Ensure that all surfaces including threads, both in the casting and on the hardware are free of dirt or debris. To ensure a proper fit, loosely assemble the entire kit before tightening the hardware.
- (A) 4. Starting with the left side mount bolt both side mounts to the tractor as illustrated. Factory equipped side rails (if equipped) remain in place under side mounts.
- (B) 5. Bolt underslung joining left and right mounts. Note: the tab on the underslung goes towards the rear.
- (C) 6. Bolt on grille guards.
- (D) 7. Attach axle mount beams to side mounts.  
NOTE: there are two brackets from the hose kit that get installed to the axle mount beams; they should be installed at this time. See hose kit instructions for further information. Mount axle mounts to rear axle. Connect axle mount beams to axle mounts. Use shims between axle mount beams and axle mounts as required. Install tension rod between side mounts and axle.
- (E) 8. Once the entire kit is in place tighten all hardware. Ensure flat washers are used where necessary.
9. The kit is now complete.
10. Kit is now ready for loader mounting. For further installation instructions see loader manual.

Letters "A" through "E" indicate recommended assembly sequence

\* Bracket 816635 is included in the kit to relocate the water heater when necessary.

\* In some cases it may be possible to improve fender clearance to the loader by removing some of the spacers under the fender mounting pads on the front axle

### **IMPORTANT:**

Read and understand all Cautions below before assembling mounting kit or operating loader. If the mounting kit components do not fit-up, please ensure to check for correct mounting kit application with that of the tractor being fitted. Common problems that can affect fit-up are row crop, transmission types, rops/cab, 2WD/4WD and etc. **Should modifications be required, you must contact the factory service department (Allied Division) for authorization and approval for any labor reimbursement.**



### **CAUTION**

Read and understand the safety messages listed in the loader operator manual. Place all controls in neutral, stop engine set parking brake and remove ignition key before inspecting, servicing, adjusting or repairing the loader.



### **CAUTION**

The tractor must be equipped with an approval Roll Over Protection Structure (ROPS) and safety belts to help prevent personal injury or death caused by tractor roll over.



### **CAUTION**

Maximum rated loader capacity may exceed tractor rating. Load restrictions or reduction in hydraulic operating pressure may be required for safe operation.

Space rear tires as recommended by the tractor manufacturer. Tire inflation and capacity must meet or exceed additional weight of loader, attachment and payload. Maximize width for high lift applications. Where noted wheel width must be less than minimum spacing recommended in the Mounting Kit List.



### **CAUTION**

Add rear ballast to help prevent personal injury or death caused by tractor roll over.

Rear ballast is required to ensure 25% of gross vehicle weight is transferred to the rear axle. Attachment and load must be included as gross vehicle weight. Adequate rear weights are required to counterbalance maximum loader rated capacity and ensure safe loader operation. Weight can be added as rear tire liquid (calcium solution), rear wheel weights, rear axle weights and/or three point hitch mounted ballast or implement. Ballasting will vary with tractor and loader attachment. Refer to the tractor manual for recommended ballasting.

## Parts List for M3949

Item	Part Number	Description	Qty
1		Left Mount	1
2		Right Mount	1
3		Underslung	1
4		Grille Guard	2
5	816640	Axle Mount RH	1
6		Axle Mount Beam	2
7	816633	Tension Rod	2
8		Grille Guard Spacer	4
9		Shim 4 x 6.5	6
10	812639	Washer Flat SAE 0.625 Bs (PI)	70
11			
12	816635	Water Heater Bracket	1
13	814109	Bolt M16 x 2 x 60	26
14	812961	Bolt Hex M16 x 2.00 x 150 10.9 (PI)	4
15	81676	Nut Hex 0.625 Nc Gr2 (PI)	20
16	81722	Nut Hex 0.875 Nc Gr2 (PI)	4
17	84335	Bolt Hex 0.625 Nc x 2.50 Gr5 (PI)	20
18	812754	Bolt Hex M16 x 2.00 x 40 Gr 10.9	4
19	813054	Bolt Hex M12 x 1.75 x 60 8.8 (PI)	8
20	816636	Axle Mount LH	1

## STEP A

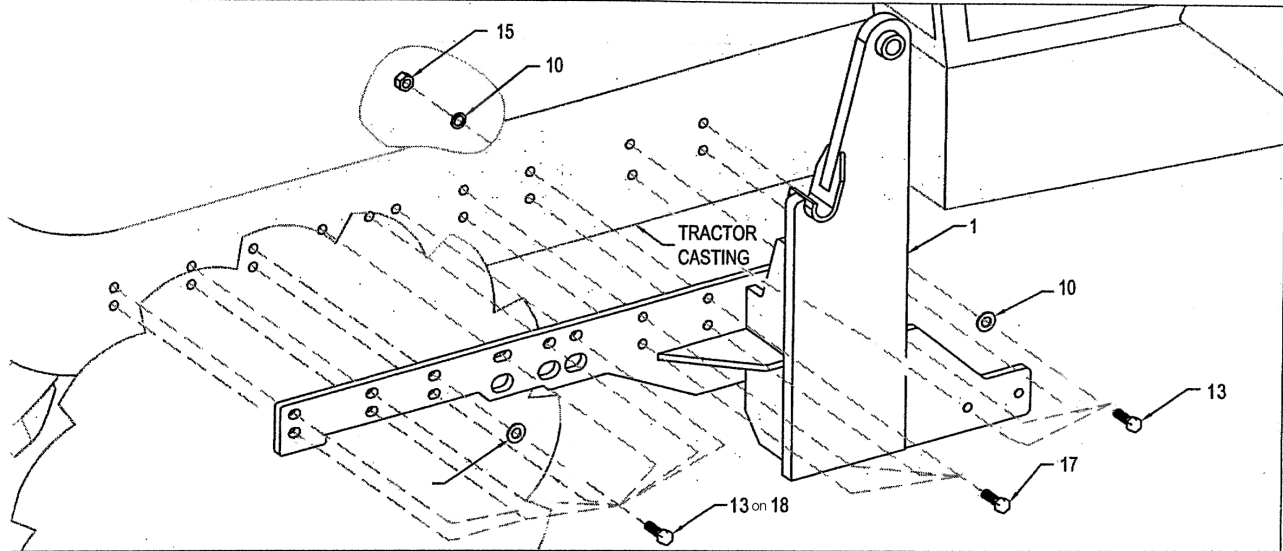

## STEP B

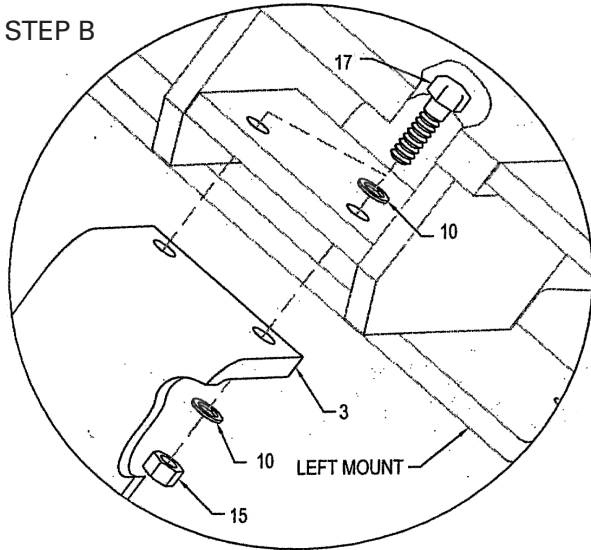

## STEP C

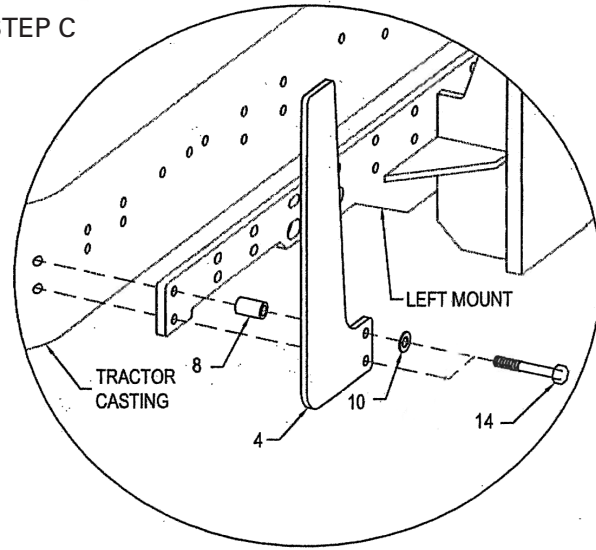

## STEP D

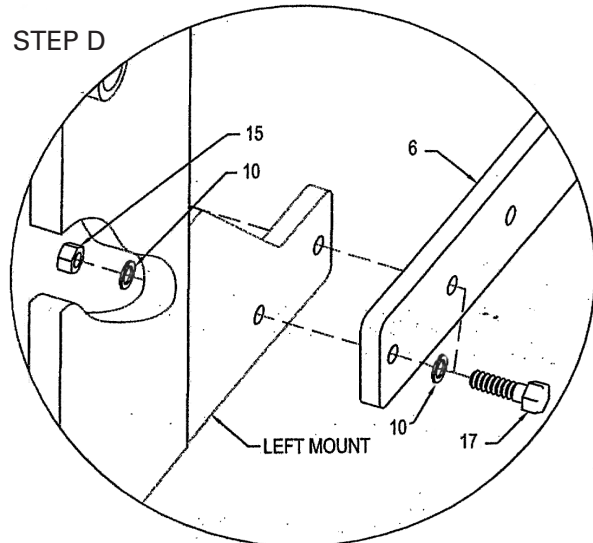

## STEP E

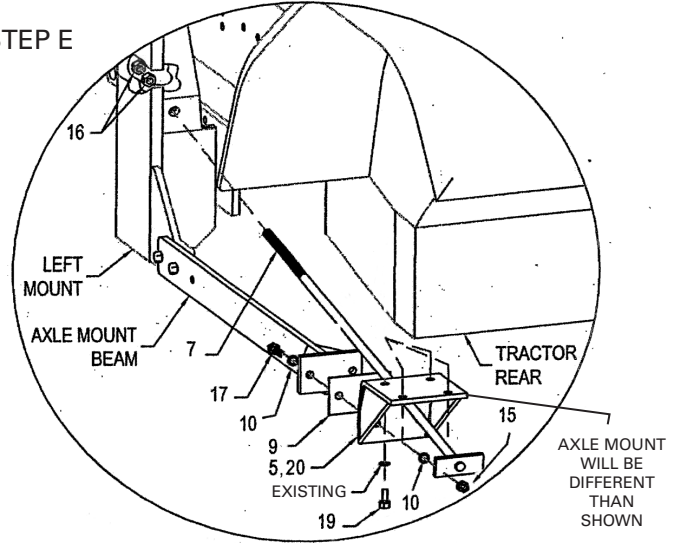

## Bolt Torque Chart

Standard						
Bolt Size (in)	Grade 2		Grade 5		Grade 8	
	Torque		Torque		Torque	
	ft-lb	NM	ft-lb	NM	ft-lb	NM
0.25	6	7	8	11	12	16
0.313	11	15	17	23	25	33
0.375	20	27	31	41	44	60
0.438	32	43	49	66	70	95
0.5	49	66	76	103	106	144
0.563	70	95	109	148	153	207
0.625	97	131	150	203	212	287
0.75	144	195	266	360	376	509
0.875	166	225	430	583	606	821
1	250	339	644	873	909	1232
1.125	354	480	795	1077	1288	1745
1.25	500	678	1120	1518	1817	2462
1.375	655	887	1470	1992	2382	3228
1.5	870	1179	1950	2642	3161	4283

Metric								
Bolt Size (mm)	Class 5.6		Grade 8.8		Grade 10.9		Grade 12.9	
	Torque		Torque		Torque		Torque	
	ft-lb	NM	ft-lb	NM	ft-lb	NM	ft-lb	NM
6	3.1	4.3	7.3	9.9	10.3	14	12.1	16.5
8	7.7	10.5	17.7	24	25	34	29	40
10	15	21	35	48	49	67	59	81
12	26	36	61	83	86.2	117	103	140
14	42	58	97	132	136	185	162	220
16	64	88	147	200	210	285	250	340
18	89	121	202	275	287	390	346	470
20	126	171	287	390	405	550	486	660
22	169	230	390	530	549	745	656	890
24	217	295	497	675	708	960	840	1140
27	320	435	733	995	1032	1400	1239	1680
30	435	590	995	1350	1401	1900	1681	2280
33	590	800	1349	1830	1902	2580	2278	3090
36	759	1030	1740	2360	2441	3310	2935	3980
39	988	1340	2249	3050	3163	4290	3798	5150

Dash Size	Thread Size	Jam Nut or Straight		SAE 37° (JIC)	
		ORB Fitting Torque		Swivel Nut Torque	
		ft-lb	NM	ft-lb	NM
-04	7/16-20	14-16	20-22	10-11	13-15
-05	1/2-20	18-20	24-27	13-15	18-20
-06	9/16-18	24-26	33-35	17-19	23-26
-08	3/4-16	50-60	68-78	34-38	47-52
-10	7/8-14	72-80	98-110	50-56	69-76
-12	1-1/16-12	125-135	170-183	70-78	96-106
-14	1-3/16-12	160-180	215-245	80-90	110-122
-16	1-5/16-12	200-220	270-300	94-104	127-141
-20	1-5/8-12	210-280	285-380	124-138	169-188
-24	1-7/8-12	270-360	370-490	156-173	212-235



3-1136 Centre St., Ste. 124,  
 Thornhill, Ontario  
 L4J 3M8 Canada  
 Tel: 1-855-246-4689 | Fax: 1-647-933-9066  
[www.mtzequipment.com](http://www.mtzequipment.com)

Equipment shown is subject to change without notice.  
 ©2013 MTZ Equipment Ltd.